

TYPE FFG

Fence Fabric Ground Clamps

Fence grounding systems are designed to provide protection against dangerous “touch” potentials. The Fence Fabric Ground Clamp is an integral component of this personnel safety system.

With its unique design the clamp can form a connection at virtually any angle. Specific uses include connection to both fence fabric and barbed wire. The conductor maintains a path to ground while connected to an object that is parallel, perpendicular or any degree in between.

Tin plated copper clamp includes stainless steel hardware and allows for use on most metallic surfaces including galvanized steel. Other sizes available; please contact factory for information.

Listed to UL 467

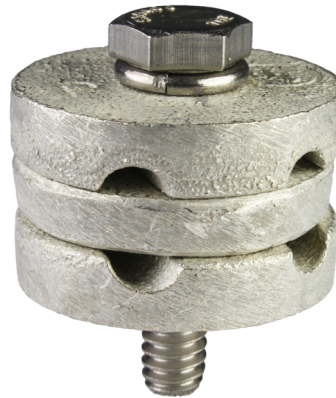
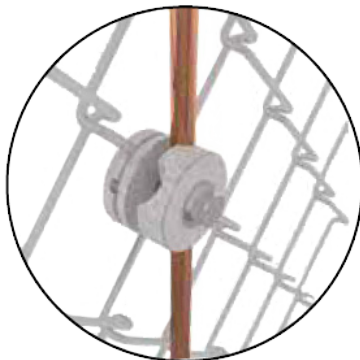

Features & Benefits

- Clamp can form connections at virtually any angle
- Tin plated copper clamp includes stainless steel hardware
- For use with most metallic surfaces including galvanized steel
- Conductor maintains path to ground while connected to object that is parallel, perpendicular or any degree in between

Catalog Number	Conductor Size	Recommended Torque (in-lb)
FFGC8	#8	67
FFGC6	#6	67
FFGC4	#4	67
FFGC2	#2	67
FFGC2/0	2/0	67

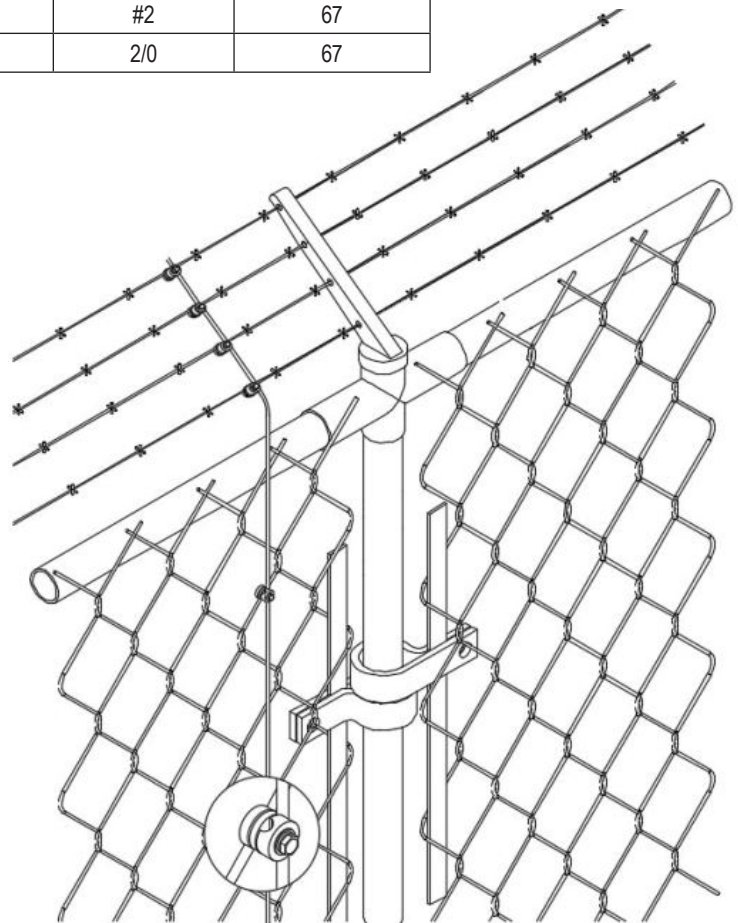

Blue highlighted items are industry standard and most frequently ordered.